

Multi Clamp

With the Multi Clamp it is possible to add a filler piece in a joint between two Logo.3 or Logo alu panels. The width of a joint can be varied steplessly between 0 and 12cm!



On a joint of 2.70m height three Multi Clamps placed on the omega profiles are necessary to tighten and perfectly align the formwork.

Advantages, Technical data

- Ergonomic design
- Adjusting range steplessly variable from 0 to 12 cm
- Robust
- Quick assembly and disassembly
- Art. No. 187.500.0004
- Weight: 5,30 kg

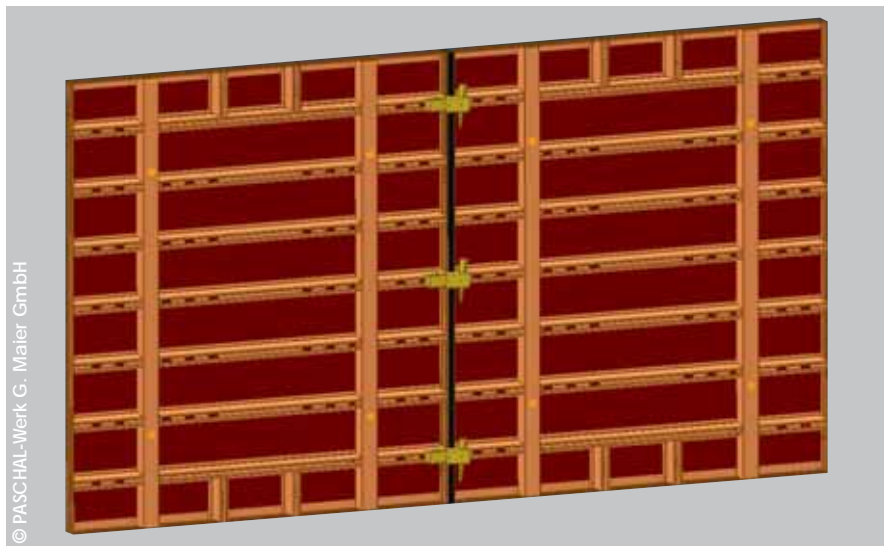

Assembly steps

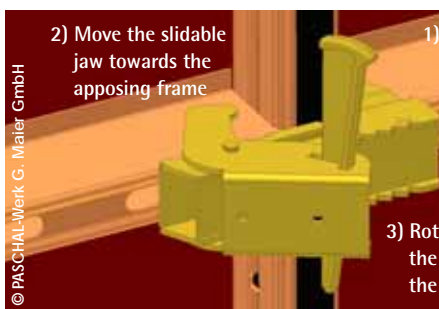
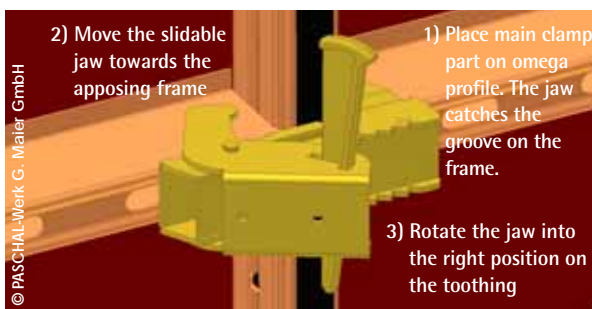

3) Rotate the jaw into the right position on the toothing

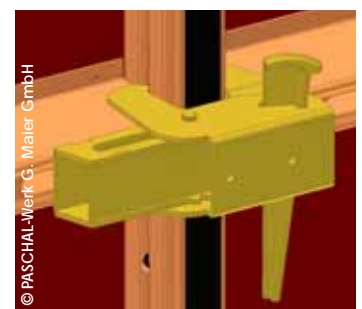
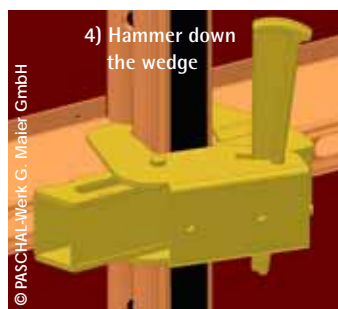

Additional information

Our product portfolio also offers 1 to 4cm plastic fillers as well as 5 to 6cm steel fillers, so that time consuming make ups can be avoided. Do feel encouraged to contact us for more information.

PASCHAL-Werk G. Maier GmbH
Kreuzbühlstraße 5 · 77790 Steinach · Germany
Phone: +49(0)7832/71-0 · Fax: +49(0)7832/71-209
service@paschal.de · www.paschal.de

You'll find our international contact addresses under:
www.paschalinternational.com

